

WELDED FITTINGS

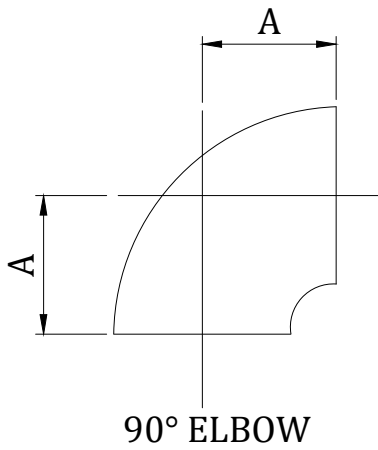

90° ELBOW

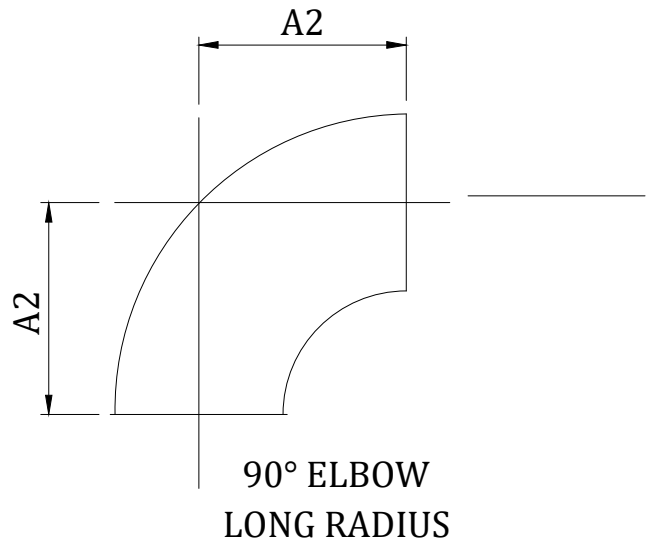

90° ELBOW
LONG RADIUS

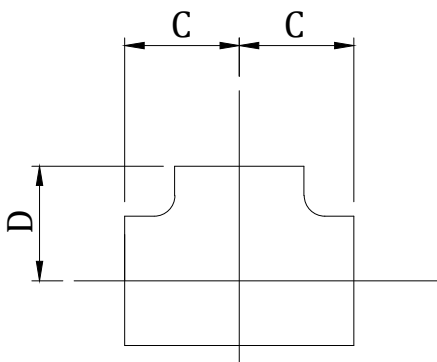
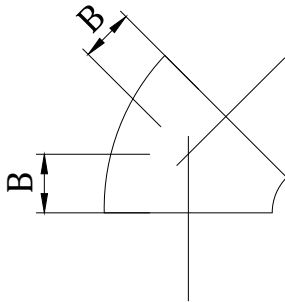

EQUAL TEES

SIZE	A	A2	B	C	D
20	19	28.5	11	28.6	28.6
25	25.5	38	22	38.1	38.1
32	32	47.5	25	47.6	47.6
40	38	57	29	57.2	57.2
50	51	76	35	63.5	63.5
65	63.5	95	45	76.2	76.2
80	76	114.5	51	85.7	85.7
90	89	133.5	57	95.3	95.3
100	101.5	152.5	64	105	105
125	127	190.5	79	124	124
150	152.5	228.5	95	143	143
203	203	305	127	178	178
254	254	381	159	216	216
305	305	457	191	254	254
356	355	533.5	222	279	279
406	406.5	609.5	254	305	305
457	457	686	286	343	343
508	508	762	318	381	381
559	559	838	343	419	419
610	609.5	914	381	432	432

Standard dimensions as
BS 1640 Part 3